

ATR 720 C

VHF TRANSCEIVER



Installation And Operation

**Handbook
No.:001.8000e**

Issue : 11/01/1999

The following
Installation and Operation
is valid for the ATR 720 C Communications Transceiver

Table of Contents

1 SECTION	GENERAL INFORMATION.....	3
1.1	INTRODUCTION.....	3
1.2	PURPOSE OF EQUIPMENT.....	3
1.3	DESIGN FEATURES.....	3
1.4	POWER REQUIREMENTS.....	3
1.5	Technical Characteristics.....	4
1.6	Units and Accessories Supplied.....	6
1.7	Accessories Required but not Supplied.....	6
2 SECTION II	Installation and Operation.....	7
2.1	General.....	7
2.2	Unpacking and Inspecting.....	7
2.2.1	Electrical Bench Test.....	8
2.2.2	Microphone Adjustment.....	8
2.2.3	Sidetone Adjustment.....	9
2.2.4	External Audio-Frequency Volume Adjustment.....	9
2.2.5	Interphone Interconnection.....	9
2.3	ATR 720 INSTALLATION.....	10
2.4	PS-2814-Installation.....	10
2.5	Antenna Installation.....	10
2.6	Cabling.....	10
2.7	OPERATION.....	13
2.7.1	General.....	13
2.7.2	ATR 720 C COMM Multifunction Control.....	13
2.7.3	POST INSTALLATION CHECKOUT.....	14

1 SECTION GENERAL INFORMATION

1.1 INTRODUCTION

This manual contains information relative to the physical, mechanical and electrical characteristics of the communications transceiver ATR 720 manufactured by Filser Electronic GmbH .

1.2 PURPOSE OF EQUIPMENT

The ATR 720 C COMM combines in a single panel mounted unit a 720 channel VHF COMM Transceiver with a microprozessor controlled frequency entry

1.3 DESIGN FEATURES

A. Controls

- Multi Function Control
- On Off Switch
- Volume Control
- Automatic squelch eliminates pilot responsivility for continuously monitoring squelch adjustment. Squelch threshold automatically adjusts to open on readable signals. SQ switch in pulled opens squelch to test COMM receiver sensitivity and to listen extremely weak signals.
- Liquid Cristal Display
- Keyboard with 15 keys for Function, Frequency Entry

B. Electronics

- Variactor diode tuned filters eliminates use of mechanical tuning shafts and mechanisms.
- Transistorized transmitter provides 4 watts minimum output power and long term reliability superior to tube designs.
- The digital frequency synthesizers utilize state of the art integrated circuits to replace all but 1 crystal.
- Crystal filter selectivity.
- Carrier controlled squelch with carrier squelch back up functionally described above.
- Tight AGC (typically 0.5 dB from μ V to 100 mV) minimizes audio level variations.

C. Construction

- Modular construction for simple maintenance.
- Rack mounted, removable from the front panel.
- Anti-theft locking mechanism.

1.4 POWER REQUIREMENTS

The ATR 720 C requires 13.75 volts for proper operation. Aircraft having electrical power plants producing 27.5 volts, require the installation of a voltage converter. The PS 2814 Voltage Converter, designed to convert 27.5 volts to 13.75 volts, may be conveniently remote mounted in the aircraft.

1.5 Technical Characteristics

ATR 720 Transceiver	
Specification	Characteristic
RTCA COMPLIANCE:	
Comm Transmitter	RTCA Do 157, Class 4 EUROCAE ED 24
Comm Receive	RTCA Do 156, Class C EUROCAE ED 23
Environmental Temperature Range Altitude	RTCA Do 160A: C4A/SM/XXXXXXZBBBB -40°C to +55°C 35.000 ft
MOUNTING:	Panel mounted, no shock mounting required
SIZE:	77x57x200 mm
WEIGHT:	8.82N (9oogr.) excluding external connectors and harness.
Power Requirements: COMM Receive COMM Transmit (Tone) CHRIYSTAL CONTROLLED: FREQUENCY RANGE: FREQUENCY STABILITY:	13.75 V (or 27.5 V with PS 2814) o1. – 0.4 amps 1.4 amps (o.8 amps unmodulated) 720 channels 118.00 to 135.975 MHz with 25 kHz spacing ± 0.002 %

ATR 720 TRANSMITTER	
Specification	CHARACTERISTICS
VHF POWER OUTPUT:	Min. 4W/50 Ω load
Modulation:	85% modulation capability with 90% limiting, less than 15 % distortion at 80 % mod.
Microphone:	Carbon or dynamic mike (adjustable)
Sidetone:	Adjustable up to 80 mw into 200 ohm

	headphones
Duty Cycle:	5 minutes on, 5 minutes off (50 %)

ATR 720 Receiver	
Specification	Characteristics
Sensitivity:	1.5 μ V will provide a 6 dB minimum signal plus noise to noise ratio
Selectivity:	Typical 6 dB at \pm 8 kHz, 70 dB at \pm 25 kHz
Spurious Responses:	Down at least 60 dB
Squelch:	Automatic squelch (carrier to noise) with manual disable and carrier squelch override.
AGC-	From 5 μ V to 20.000 μ V audio output will not vary more than 0.5 dB.

Audio	
Specifications	Characteristics
External Audio Input:	External Audio-Frequency input with adjustable sensitivity (10 mV – 1 V for rated speaker output)
Frequency Responses:	Within 6 dB from 350 Hz to 2500 Hz. Min 18 dB down at 5000 Hz.
Headphone Output:	80mW into 200 Ω
Speaker Output:	3 Watts audio output
Interphon:	Interphone capability with external switch (refer to appropriate electrical installation diagram in Section 2) . .

Voltage Converter PS 2814	
Specification	Characteristics
Weight:	4,2N (430 gr.)
Power-Input Volts	27,5 VDC
Power-Output Volts	13,75 VDC
Output Current continuous	2,0 A
Output Current 50% duty	5,0 A

1.6 Units and Accessories Supplied

- ATR 720 COMM
- ATR 720 C installation kit includes mating connectors, radio rack mounting hardware, etc.

1.7 Accessories Required but not Supplied

- Communication antenna and cables
- Headphones and speaker
 - Headphones: Low impedance types, 200 to 1000 ohms.
 - Speaker: Voices coil impedance 4 to 8 ohms nominal.
- PS 2814 Voltage Converter, 27.5 V to 13.75 V (required in 27.5 V installation only).
- Microphone: Low impedance carbon, or dynamic with transistor pro-amp, when using „Carbon-Mike-adjustment“, low impedance dynamic microphone when using „Dynamic-Mike-adjustment. Refer to § 2.2.2.
- Interconnection with Main Plug Unit BB9 and BS9. This is an useful help to connect the ATR 720 C COMM to external accessories.

2 SECTION II Installation and Operation

2.1 General

This section contains suggestion and factors to consider before installing the ATR 720 COMM unit and PS 2814 Voltage Converter (27.5 V installations only). Close adherence to these suggestions will assure a more satisfactory performance from the equipment.

2.2 Unpacking and Inspecting

Exercise extreme care when unpacking each unit. Make a visual inspection of each unit for evidence of damage incurred during shipment. If a claim for damage is to be made, save the shipping container to substantiate the claim. When all equipment is removed, place in the shipping all packing materials for use in unit sortage or reshipment. The ATR 720 installation will conform the standards designated by the customer, installing agency and exiting conditions as to unit location and type of installation.

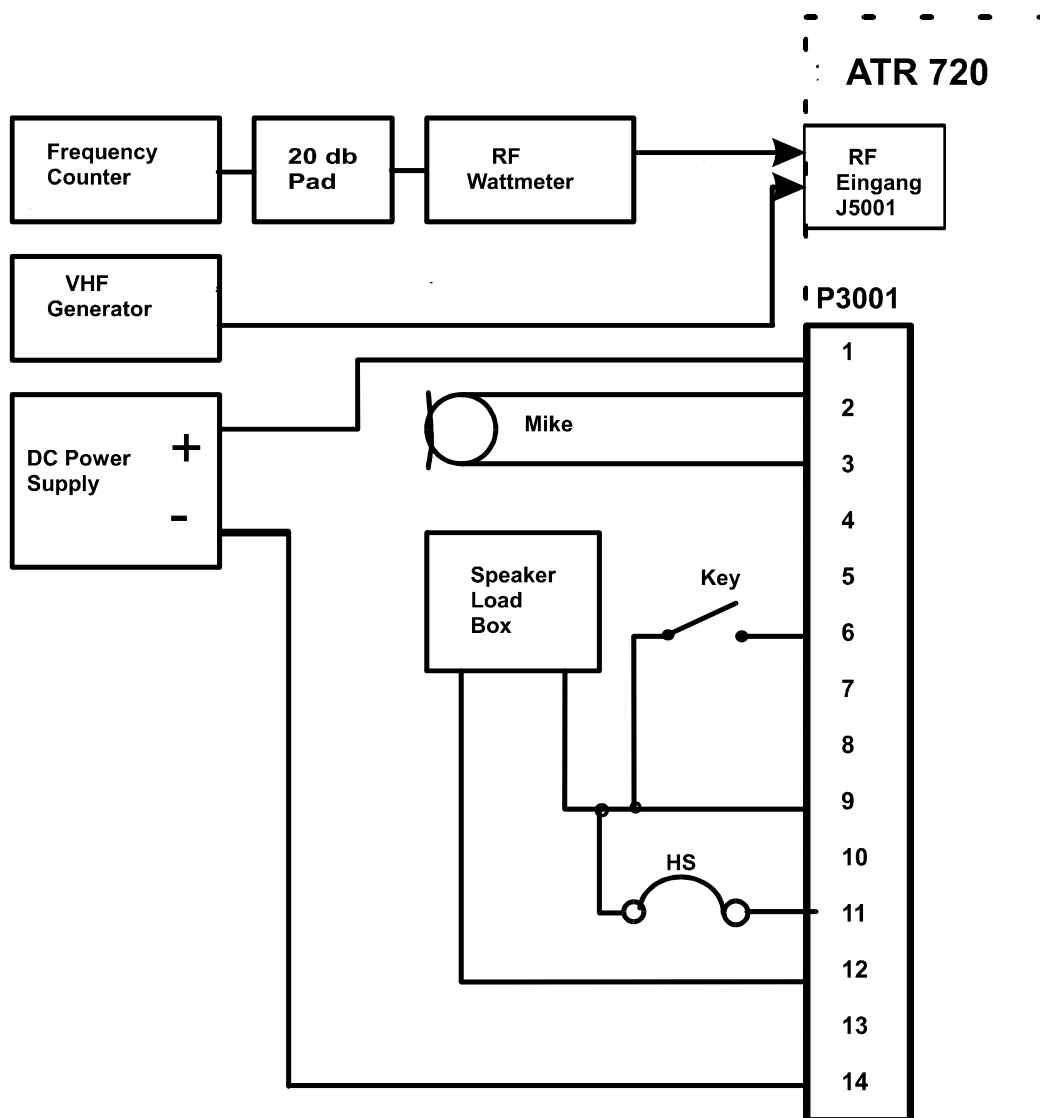

Figure 2-1 BENCH TEST SET-UP

Figure 2.1

2.2.1 Electrical Bench Test

Test Equipment Recommended

1. VHF Signal Generator: HP Model 608D or equivalent.
2. RF Power Wattmeter: Bird Truline Model 43 or equivalent.
3. Regulated DC Supply with 12 to 15 Vdc at 2 amperes capability.
4. Frequency Counter: HP Model 5383 A or equivalent.
5. Oscilloscope: National VP 5510 A or equivalent
6. Speaker Load Box: with 4 watt capability.
7. watt pad, 20dB, 20W
8. Audio-Detector: Texscan Model DC-50 or equivalent.
9. Low Impedance microphone that will be used in the aircraft.

2.2.1.1 Test Procedure

1. Connect the Comm Unit into the test set-up, diagramed in Figure 2-1, and set the DC supply for 13,75 VDC.
2. Connect the VHF signal generator to J 5001, set the generator output level to 1.5 μ V with 30 % - 1 kHz modulation.
3. Set the COMM VOLUME CONTROL for a 100 mw reading on the speaker load box meter.
4. Remove the modulation, look for a 6 dB change on the speaker load box meter.
5. Disconnect the signal generator. Connect the RF wattmeter and frequency counter as diagramed in Figure 2-1.
6. Connect the wattmeter to J 5001. Key the transmitter and talk into the microphone. The wattmeter indicator should react with a wiggle.
7. With the transmitter keyed, use the frequency counter to check the Unit's frequency programming. Check all kHz steps from 118.000 MHz to 118.975 MHz and all MHz steps from 118.000 MHz to 135.000 MHz.
8. Check by switching the memory preselector if the four memories are preselected. The Frequency display shows 100.00 MHz when the memory battery is unserviceable or empty. In this case all four preselected channels will be cleared by switching off the radio.

2.2.2 Microphone Adjustment

It is recommended that the microphone adjustment (see Figure 2-2) be performed while the Unit is on the bench using the aircraft's microphone(s). This adjustment can be made in the aircraft, however, it would require removal and insertion of the unit since the MIKE SELECTOR is located on the side of the chassis. Should the aircraft be equipped with more than one microphone, the type of microphones should be identical.

Adjustment:

1. Dynamic Microphone

Using a low impedance dynamic microphone (200 ohms) turn the microphone gain trim-potentiometer R 3104 full

- clockwise -

Note: This position is preset by the manufacturer

2. Carbon Standard Microphone or Dynamic Microphone with Preamplifier

Using a carbon standard microphone or a dynamic microphone with preamplifier turn the microphone gain trim-potentiometer R 3104 full

- counter clockwise -
-

Caution Do not force microphone selector

2.2.3 Sidetone Adjustment

1. Connect the Unit into the test set-up diagramed in Figure 2-1.
2. Connect the RF wattmeter or a suitable dummy load to J 5001.
3. Key the transmitter and talk into the microphone.
4. Adjust SIDETONE control 5201 for a comfortable listening level from the headphones.
5. Disconnect the Unit from the test set-up.

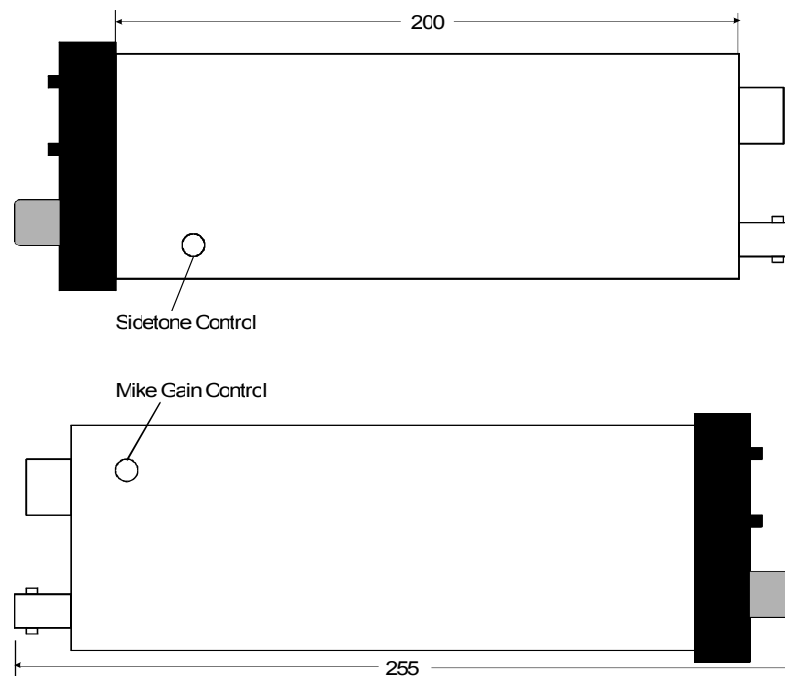

Figure 2.2 MIKE SELECTOR - SIDETONE CONTROL

2.2.4 External Audio-Frequency Volume Adjustment

When using the external audio-Frequency input (P 3001 Pin 4), the sensitivity of this input may be adjusted with R 3107, which is located on the Audio-Frequency/Synthesizer board. R 3107 is pre-adjusted to 0.5 V RMS sensitivity for rated speaker output, which is sufficient in the most cases. For further details of adjustment see „ATR 720 – Maintenance Manual“ § 4.5.4 and Figure 6-3. Turning R 3107 clockwise, the sensitivity of this input is to be increased.

2.2.5 Interphone Interconnection

For Interphone wiring see ATR Interconnect diagram. An external double-pole switch is recommended.

2.3 ATR 720 INSTALLATION

Listed below are factors and suggestions to consider before installing your ATR 720 C system. Close adherence to these suggestions will assure more satisfactory performance from your equipment.

1. The ATR 720 C is mounted rigid in the aircraft panel. Determine that the location and installation of radio equipment provides sufficient visibility and handling of the controls for the pilot in his normal position. Mark and cut the mounting holes as shown in Figure 2-3. The purpose of the behind aircraft mount cutout is to allow a margin of error in cutout size and prevent the mounting tray front edge from being visible. The mounting tray lip should extend through the mounting hole flush with the instrument panel to insure proper plug in engagement.
2. Avoid mounting close to any high external heat source. If this is done, no blower or ram air cooling will be required.
3. Remember to allow adequate space for installation of cables and connectors.
4. Secure the mounting rack to instrument panel per Figure 2-3. The rearward mounting holes must be attached to a structural member of the panel by means of support brackets, in order to avoid vibration.
5. Slide the ATR 720 C into the rack and secure by turning locking screw on the rear panel.

- **Caution** Do not force locking tab screw.

6. The installing agency will supply and fabricate all external cables. The plugs required are supplied.

2.4 PS-2814-Installation

1. Select the PS 2814 location considering good thermal conductivity to the airframe, convenient cable routing, proximity to the ATR 720 C and separation other heat sources.
2. Refer to Figure 2-4 for the PS 2814 mounting dimensions.
3. Secure the PS 2814 firmly in place. Service
4. The installing agency will supply and fabricate external cables.

2.5 Antenna Installation

- a. A conventional 50 ohm vertically polarized COMM antenna is required with the ATR 720. Vertical bent whip antennas are not recommended. Wideband COMM antennas provide efficient operation over the COMM band. Antennas should be installed per manufacturer's recommendations. Additional recommendations are as follows:
 1. Mount antenna on flat metal surface or install a ground plane at least 50 cm x 50 cm.
 2. The antenna should be well removed from any projections and the engine(s) and propeller.
 3. The COMM antenna should be well separated from any NAV Antenna to minimize COMM interference to NAV while transmitting.
- b. Refer to Figure 2-5 for the COMM antenna cable connector assembly.

2.6 Cabling

1. The length and routing of the external cables must be carefully studied and planned prior to installation. Avoid sharp bends placing cables near the aircraft control cables.

2. Fabricate the external cables in accordance with the installation drawing that fulfills the system requirement.

NOTE –

Use good quality stranded wire that will not support a flame and with at least 600 volt insulation. It is recommended that the mike audio line is shielded.

Since other radio equipment will possibly utilize the same speaker circuits for muting, speaker selection and microphone switching must be devised by the installing agency.

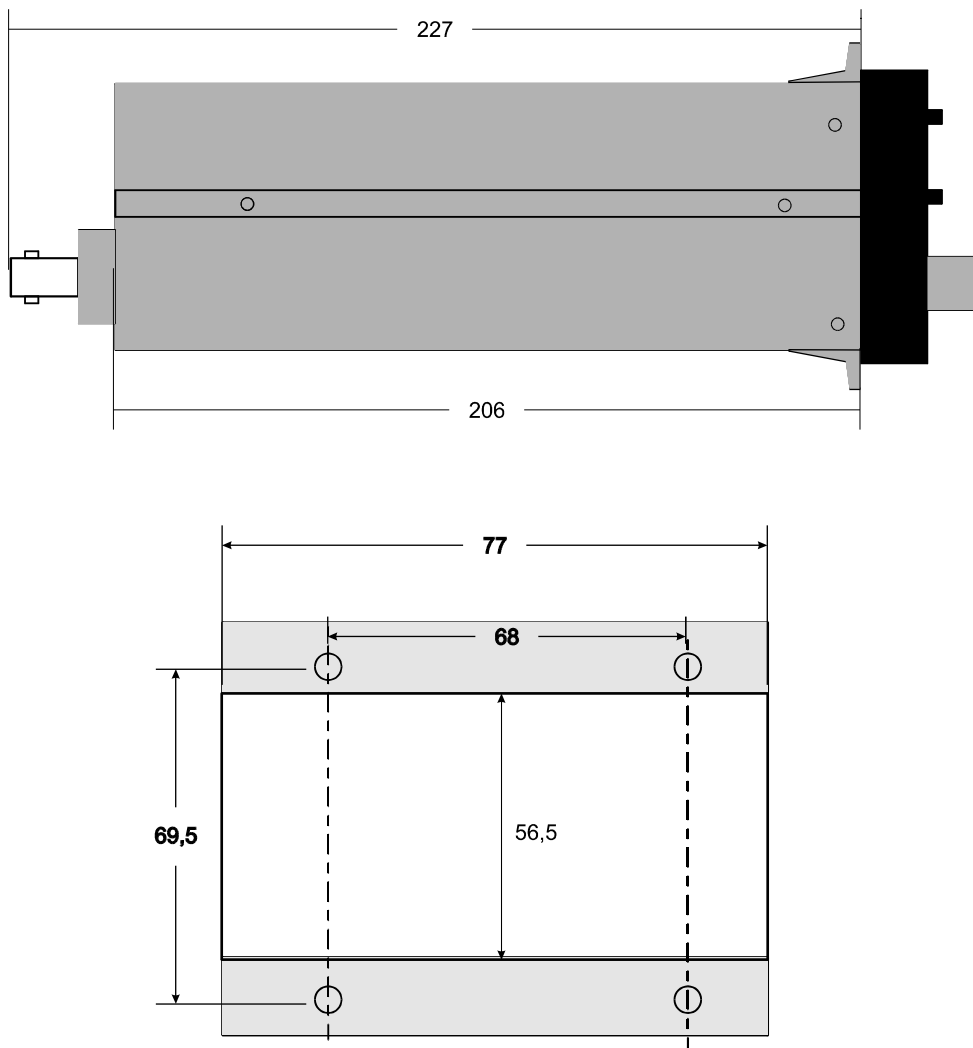

Figure 2.3 Outline and mounting Drawing

All dimensions in mm

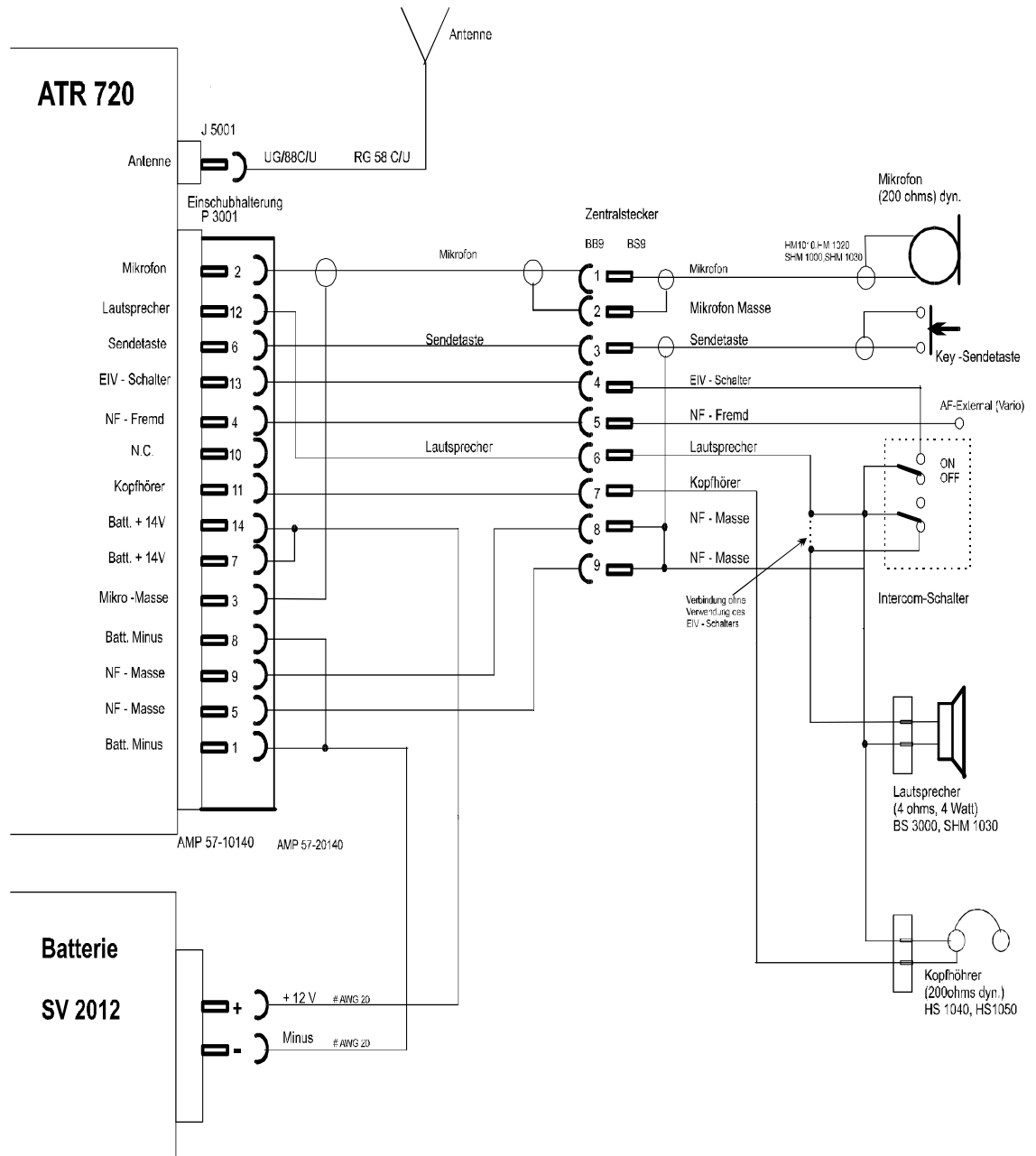

FIGURE 2-6.1 INTERCONNECTION DIAGRAM

2.7 OPERATION

2.7.1 General

All controls required to operate the ATR 720 C are located on the front panel.

2.7.2 ATR 720 C COMM Multifunction Control

2.7.2.1 Comm – On/Off-Switch-Multifunction Control

The multifunction- ON/OFF-switch is located in the upper Right-hand corner. The transceiver is activated the switch is turned clockwise beyond the „off-position click“.

2.7.2.2 Squelch Control

While in the pushed-in position (Automatic mode) weak signals and noise are being suppressed. The Squelch-ON-Test position (pulled-out) is used to receive weak signals and to the squelch.

2.7.2.3 Volume Control –VOL-

The Volume control –VOL- is activated at the multifunction -control by turning it clockwise for the desired volume.

2.7.2.4 COMM – Keyboard

The COMM Keyboard consists of five function-keys and 10 number-keys 1 – 0. The decimal point is fixed and appears after pressing the number „1“.

Description of the various function-keys. From left to right:

E ENTER serves for the entry i.e. activation of a preselected, desired frequency (simultaneously displayed in the LCD-Frequency display). After pressing the E-Key the receiver is activated and the transmitter ready for operation at the selected frequency.

ST STORE is required to load an activated frequency into the frequency-memory. Depressing the ST-Key followed by one of the number-keys 1 – 0 stores the programmed frequency into the respective storage location. (1 – 10).

Note: The preselected frequency, which is shown in the display, will be automatically entered after the last digit is given in by a number key.

RM RECALL MEMORY. With the RM-Key one of the stored frequencies may be recalled at any time. This is achieved by depressing the RM-Key followed by one of the ten number-keys (1 – 0 frequency-locations). The memory is maintained even when the unit is switch off.

CL CLEAR. Depressing the CLEAR-Key erases the activated frequency. At the same time the LCD-display is cleared. A new frequency may now be selected.

2.7.2.5 Frequency Display

The frequency is displayed 7 mm's high on a 5-digit liquid-crystal display.



2.7.3 POST INSTALLATION CHECKOUT

An operational performance flight test is recommended after the installation is completed to insure satisfactory performance of the equipment in its normal environment. To check the communications transceiver, maintain an appropriate altitude and contact a ground station facility at a range of at least fifty nautical miles. Contact a ground station close in. Place the squelch knob in the test position and listen for any unusual electrical noise which would reduce the COMM receiver sensitivity by increasing the squelch threshold. If possible, verify the communications capability on both the HIGH and LOW ends of the VHF COMM band.